

*Chemistry*  
*Analytical Chemistry fields*

---

Okayama University

Year 2008

---

Development of novel detection reagent  
for simple and sensitive determination of  
trace amounts of formaldehyde and its  
application to flow injection  
spectrophotometric analysis

Qiong Li\*  
Mitsuko Oshima<sup>‡</sup>

Piyanete Sritharathikhum<sup>†</sup>  
Shoji Motomizu\*\*

\*Department of Chemistry, Faculty of Science, Okayama University

<sup>†</sup>Department of Chemistry, Faculty of Science, Okayama University

<sup>‡</sup>Department of Chemistry, Faculty of Science, Okayama University, oshimam@cc.okayama-u.ac.jp

\*\*Department of Chemistry, Faculty of Science, Okayama University, motomizu@cc.okayama-u.ac.jp

This paper is posted at eScholarship@OUDIR : Okayama University Digital Information Repository.

[http://escholarship.lib.okayama-u.ac.jp/analytical\\_chemistry/17](http://escholarship.lib.okayama-u.ac.jp/analytical_chemistry/17)

**Development of novel detection reagent for simple and sensitive determination of trace amounts of formaldehyde and its application to flow injection spectrophotometric analysis**

**Qiong Li, Piyanete Sritharathikhum, Mitsuko Oshima, Shoji Motomizu\***

*Department of Chemistry, Faculty of Science, Okayama University, 3-1-1 Tsushimanaka, Okayama 700-8530, Japan*

\* Corresponding author. Tel.: +81-86-251-7846; Fax: +81-86-251-7846.

*E-mail address: motomizu@cc.okayama-u.ac.jp (S. Motomizu).*

**Abstract**

In this paper, a novel detection reagent for formaldehyde determination is proposed, and is applied to a simple and highly sensitive flow injection method for the spectrophotometric determination of formaldehyde. The method is based on the reaction of formaldehyde with methyl acetoacetate in the presence of ammonia. The increase in the absorbance of the reaction product was measured at 375 nm. An inexpensive light emitting diode (LED)-based UV detector (375 nm) was, for the first time, used. Under the optimized experimental conditions, formaldehyde in an aqueous solution was determined over the concentration range from 0.25 - 20.0 x 10<sup>-6</sup> M with a liner calibration graph; the limit of detection (LOD) of 5 x 10<sup>-8</sup> M (1.5 µg L<sup>-1</sup>) was possible. The relative standard deviation of 12 replicate measurements of 5x10<sup>-6</sup> M formaldehyde was 1.2 %. Maximum sampling throughput was about 21 samples / h. The effect of potential interferences such as metals, organic compounds and other aldehyde was also examined. The analytical performance for formaldehyde determination was compared with those obtained by the conventional acetylacetone method, which uses visible absorption spectrophotometry. Finally, the proposed method was successfully applied to the determination of formaldehyde in natural water samples.

*Keywords:* Flow injection; Formaldehyde determination; Spectrophotometry; Methyl acetoacetate; UV-light emitting diode (LED)

## **1. Introduction**

Formaldehyde (HCHO) is the most abundant gas-phase carbonyl compound in the atmosphere, and is a colorless and strong-smelling gas under normal conditions, and is soluble in water. Formaldehyde is a very toxic compound and has been classified as a human carcinogen (cancer-causing substance) by the International Agency for Research on Cancer, and also as a probable human carcinogen by the U.S. Environmental Protection Agency [1]. Skin contact with formaldehyde solution can cause irritation, and drying and reddening of the skin. Long-term contact with formaldehyde can cause sensitization of the skin, resulting in a rash or eczema. Eye irritation may occur at formaldehyde concentrations of about  $0.2 \text{ mg L}^{-1}$ , and tears will form at about  $4 - 5 \text{ mg L}^{-1}$ . Massive and intolerable tear formation occurs at concentrations higher than about  $10 \text{ mg L}^{-1}$  in most people. Contact of the eyes with concentrated formaldehyde solutions can cause severe eye irritation, injury and possible blindness. Swallowing of formaldehyde solution is unlikely, but if it occurred, it would result in irritation and severe pain in the mouth, throat, and digestive tract [2]. Formaldehyde is very active, and is transported in air, water and contaminated soils. In aqueous systems, atmospheric deposition is a significant source of formaldehyde, since formaldehyde concentration in rainwater is higher than those in

surface waters, by three orders of magnitude, or more [3]. Formaldehyde in drinking water arises mainly from the oxidation of natural organic (humic) matter during ozonation [4] and chlorination [5]. It also enters drinking water via leaching from polyacetal plastic fittings in which the protective coating has been broken [6]. Formaldehyde concentrations have been found up to  $30 \mu\text{g L}^{-1}$  in ozonated drinking water [7, 8]. In a study, which was carried out in Taiwan, formaldehyde concentrations in bottled and packed drinking water were lower than  $129 \mu\text{g L}^{-1}$ , which were all below the detection limit of the analytical method used for the investigation [9]. Furthermore, in Japan, the maximum concentration of formaldehyde in drinking water is regulated at less than  $80 \mu\text{g L}^{-1}$  ( $2.7 \mu\text{M}$ ) [10]. Recently, the high chemical reactivity of formaldehyde has caused an increasing serious problem on human health.

For the determination of formaldehyde, a number of methods have been proposed so far. In general, in an aqueous environment, most of the proposed methods for the determination of formaldehyde require the derivatization with various reagents prior to their measurement, which can form colored products and can be detected spectrophotometrically. Of these, numbers of the methods are based on the reaction of formaldehyde with 2,4-dinitrophenylhydrazine (2,4-DNPH) to form hydrazone [11]. However, 2,4-DNPH can react with many aldehyde and ketones, and the 2,4-DNPH derivatization reaction takes one hour for a complete reaction. The chromotropic acid

(1,8-dihydroxynaphthalene-3,6-disulphonic acid) method [12-14], MBTH (3-methyl-2-benzothiazolone hydrazone) method [15-17], AHMT (4-amino-3-hydrazino-5-mercapto-1,2,4-triazole) [18-20] and pararosaniline method [21-24] are popular colorimetric methods for the detection of formaldehyde. In these method, however serious problems are present; for example, the chromotropic acid method needs hot concentrated sulphuric acid [12] or a less harmful mixture of HCl and H<sub>2</sub>O<sub>2</sub> [25]. The MBTH method has been less commonly used because it is very expensive and can react easily with other aldehydes, and the sample solutions should be measured immediately after sampling due to the instability of the MBTH– formaldehyde intermediate [26, 27]. The AHMT method needs a very strong base as the reaction medium, which is not desirable especially as carbonate formation will occur. In the method using pararosaniline-based Schiff reaction, color development is relatively slow and sensitivity is not so good [28]. A fairly sensitive fluorimetric method, based on the reaction of formaldehyde with 3,4-diaminoanisole to form a fluorescent Schiff base, has also been reported. The method, however, needs a refluxing process, which is very tedious [29].

One of other widely used derivatization reaction is a Hantzsch reaction, which is based on the derivatization of formaldehyde with  $\beta$ -diketone, in which 2,4-pentanedione (acetylacetone) [30, 31], 5,5-dimethyl-1,3-cyclohexanedione (dimedone) [32],

1,3-cyclohexanedione (CHD) [32], 4-amino-3-pentene-2-one (Fluoral-P) [33], and acetoacetanilide (AAA) [34] have been used as derivatization reagents. These methods are relatively sensitive and selective for formaldehyde. However, the procedure by a batchwise method needs long reaction times and can not be simply adopted for an automatic analysis. In order to develop a simple and automated method of analysis for formaldehyde, a flow injection analysis (FIA) method has been frequently used. Li et al. proposed a fluorometric flow injection system using CHD as the reagent [35]. The sensitivity of CHD system is very good; LOD is 10-15 nM. Sakai et al. developed a highly sensitive fluorometric FIA system with dimedone, and measured gaseous formaldehyde after absorbing in aqueous solution [36]. Later, our colleagues developed an on-line collection/concentration of trace amounts of formaldehyde with chromatomembrane cell (CMC) and its on-line determination by a fluorometric flow injection technique using acetylacetone method [37]. The method with acetylacetone system can measure formaldehyde as low as  $8 \times 10^{-9}$  M ( $0.2 \mu\text{g L}^{-1}$ ). Such fluorometric methods for formaldehyde determination require high reaction temperatures, so that high backpressure, a postcooling device or a debubbling diffusion cell are necessary to prevent the bubble generation and the increase in consequent noise. Recently, a flow injection fluorometric detection method with acetoacetanilide was developed by the authors [38]. The method can be carried out at room temperature; the detection limit is  $3 \times 10^{-9}$  M ( $0.09 \mu\text{g L}^{-1}$ ). In these

fluorometric methods, an expensive instrument as a detector is needed. Moreover, organic solutions such as acetonitrile, acetone or ethanol are necessary.

In the determination of trace amounts of formaldehyde in water, in general, some enrichment procedures are always used for the preconcentration of formaldehyde before measurement [39-41]. Therefore, a simple and highly sensitive method for formaldehyde determination is required for the direct analysis of water samples without any preconcentration techniques.

In this work, a novel detection reagent, methyl acetoacetate (MA), was proposed for the determination of formaldehyde. The reaction can take place in a mild aqueous solution. A simple flow injection system, consisting of a pumping system, a sample injection valve, a reaction coil, a heating system and a LED detector (375 nm) for the formaldehyde determination in natural water was developed.

## **2. Experimental**

### *2.1. Reagents*

All reagent solutions were prepared using purified water from a Milli-Q Labo system (Elix 3/Milli-Q Element, Nihon Millipore Corp., Japan) and all the reagents used in this work were of analytical reagent grade.

A 0.10 M standard solution of formaldehyde was prepared by diluting 0.78 ml of 36.0-38.0% formaldehyde solution (Wako Pure Chemicals, Osaka) to 100 ml with purified

water, followed by an accurate concentration determination using the iodometric method [42]. The working standard solutions were prepared by accurate dilution of the standard stock solution just before use.

A 0.2 M methyl acetoacetate stock solution was prepared by diluting 2.15 mL of commercially available methyl acetoacetate solution (Tokyo Kasei, Tokyo) to 100 mL with purified water.

An ammonium acetate stock solution was prepared by dissolving 77.1 g of ammonium acetate (Wako Pure Chemicals, Osaka) in the purified water and diluting it to 250 ml with purified water.

The following buffer solutions were used to adjust pH of the solutions: acetate buffer (acetic acid–sodium acetate) for the pH range of 3.0–7.0, prepared by mixing 2.0 M acetic acid and 2.0 M sodium acetate solution; phosphate buffer (disodium hydrogenphosphate – potassium dihydrogenphosphate) for pH 5.5–8, prepared by mixing 2 M disodium hydrogenphosphate and 2 M potassium dihydrogenphosphate.

For interference testing, the following compounds were used: sodium chloride, sodium nitrate, sodium nitrite, sodium sulfate, sodium sulfite, sodium carbonate, copper (II) chloride, iron (III) nitrate, hydrogen peroxide, acetic acid, acetone, propionaldehyde and acetaldehyde. All these chemicals were purchased from Wako Pure Chemicals (Osaka, Japan).



## *2.2. Apparatus*

### *2.2.1. UV-VIS equipment*

For absorption spectra and absorbance measurements, a UV-2400 PC double beam spectrophotometer from Shimadzu (Japan) furnished with 1.0 cm pathlength quartz cell was used: absorption spectra were registered from 300 to 500 nm.

### *2.2.2. Flow-injection detection system*

A schematic diagram of employed flow-injection analysis system is presented in Fig. 1. A double-plunger pump (Sanuki Kogyo, RX-703T, Japan), P, was used for propelling a carrier solution (CS) and a reagent solution (RS). A six-way switching valve (Sanuki Kogyo, Japan), V with a loop, was used for introducing standard formaldehyde solutions and samples into the carrier stream. Flow lines were made of PTFE tubings (0.5 mm i.d.). A thermostating dry bath (Iuchi, EB-303, Japan) was used throughout the whole experiment. The signal was measured with a UV-LED-based detector with an interference filter of 375 nm (AT-500), which was specially assembled collaborately with Moritani et al. of Artech Co. Ltd., Japan, and saved in a personal computer using a FIA monitor/data processing apparatus (F.I.A. Instrument, Tokyo, Japan)

A pH meter (Mettler Toledo, MP220, Switzerland) was used for adjusting pH of the reagent solution. All measurements were performed in a temperature-controlled room ( $25.0 \pm 0.1^\circ\text{C}$ ).

## *2.3. Derivatization procedure by batchwise method*

To a 10 mL calibrated flask was transferred 5 mL of 4.0 M ammonium acetate (pH =7.2), 2.5 mL of 0.2 M methyl acetoacetate, and a series of standard formaldehyde solutions, and then the mixtures were diluted to the mark with purified water. The mixed

solution was lead to react for 10 min at 60 °C in a water bath, and then cool down in water for 5 min. Finally, the reaction mixture was transferred to a quartz cell for the measurement of absorbances; the absorbance of the reagent blank and the sample solutions were measured at 375 nm.

#### 2.4. Flow injection procedure

For a simple, rapid and continuous determination of formaldehyde, the proposed detection reaction was applied to flow injection analysis. Fig. 1 shows the flow injection system used in this work. The procedure was started by flowing the carrier and the reagent solution at a flow rate of 0.4 ml min<sup>-1</sup> through the PTFE tubings until a stable baseline signal was achieved, at this point, 300 µl of working standard solutions of formaldehyde were introduced into the carrier stream through a six-way injection valve. The standard formaldehyde solutions are mixed with the reagent solution, and flowed into the reaction coil (RC). Then, absorbance change of the reaction product was measured with a UV light emitting diode (LED)-based detector (375 nm); the resulting peaks were recorded with a FIA monitor/data processing apparatus.

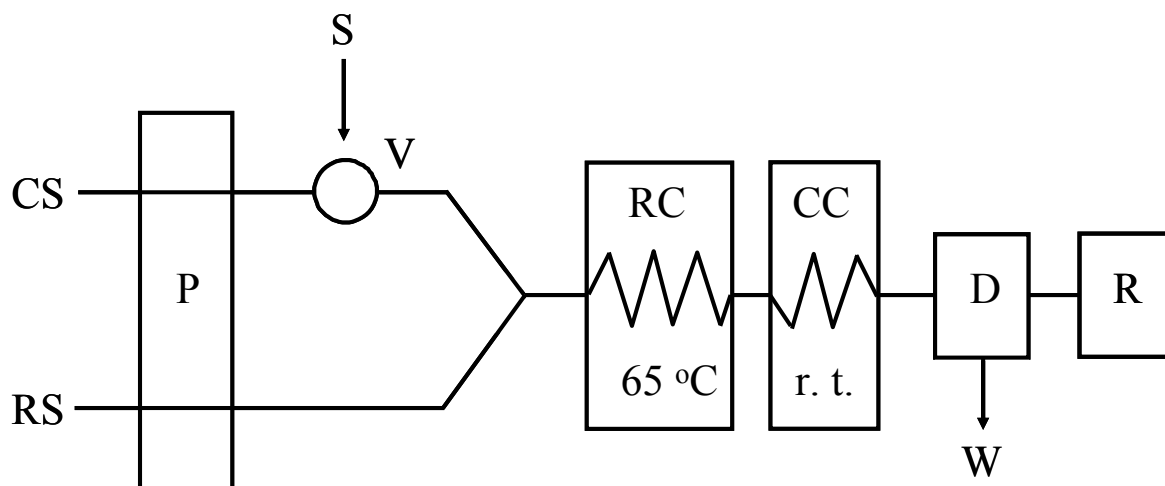

**Fig. 1** FIA system for the determination of formaldehyde using methyl acetoacetate as a reagent.

CS: carrier solution (purified water); RS: 0.1 M methyl acetoacetate and 1.0 M ammonium acetate solution at pH 7.0; P: pump RX-703T; V: six-way valve with 300  $\mu$ l loop; RC: reaction coil (8 m x 0.5 mm i.d.); CC: cooling coil (2 m x 0.5 mm i.d.); D: LED detector; R: recorder.

### 3. Results and discussion

#### 3.1. Development of novel reagent for Hantzsch's reaction

The detection reaction is based on the Hantzsch reaction, which was first explained by Nash [30]. In this work, several kinds of commercially available  $\beta$ -keto esters such as methyl acetoacetate, ethyl acetoacetate, n-propyl acetoacetate, n-amyl acetoacetate, malonic acid, dimethyl malonate and diethyl malonate were examined by using spectrophotometric methods at room temperature and 60 °C. The obtained maximum wavelength and the apparent molar absorptivity of their products obtained under each experimental reaction condition are shown in Table 1. Of these reagents, methyl acetoacetate gave the largest molar absorptivity ( $5 \times 10^3 \text{ dm}^3\text{mol}^{-1}\text{cm}^{-1}$  at room temperature and  $7.8 \times 10^3 \text{ dm}^3\text{mol}^{-1}\text{cm}^{-1}$  at 60 °C). Moreover, methyl acetoacetate is one of the most soluble reagents in water: it is most reactive with formaldehyde, selective and sensitive for formaldehyde by spectrophotometry. The reaction of the color development proceeds through the following steps: one molecule methyl acetoacetate can react with formaldehyde, and the other one can react with ammonia to form an enamine-type

intermediate; subsequent cyclodehydration can give a product, 2,6-dimethyl-1,4-dihydropyridine-3,5-di(methylcarboxylate). The reaction mechanism was shown in Scheme 1.

**Table 1** Some promising reagents and apparent molar absorptivity ( $\epsilon$ ) of their products

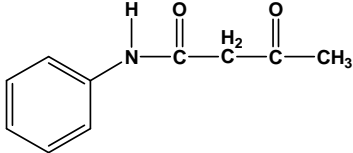
Reagents	Structure	$\epsilon / \text{dm}^3 \text{ mol}^{-1} \text{ cm}^{-1}$ 25°C	$\epsilon / \text{dm}^3 \text{ mol}^{-1} \text{ cm}^{-1}$ 60°C	$\lambda_{\text{max}} / \text{nm}$
Methyl acetoacetate	$\text{H}_3\text{C}-\overset{\text{O}}{\parallel}{\text{C}}-\text{CH}_2-\overset{\text{O}}{\parallel}{\text{C}}-\text{O}-\text{CH}_3$	5000	7800	372
Ethyl acetoacetate	$\text{H}_3\text{C}-\overset{\text{O}}{\parallel}{\text{C}}-\text{CH}_2-\overset{\text{O}}{\parallel}{\text{C}}-\text{O}-\text{C}_2\text{H}_5$	3000	5500	376
n-Propyl acetoacetate	$\text{H}_3\text{C}-\overset{\text{O}}{\parallel}{\text{C}}-\text{CH}_2-\overset{\text{O}}{\parallel}{\text{C}}-\text{O}-\text{C}_3\text{H}_7$	600	1800	354
n-Amyl acetoacetate	$\text{H}_3\text{C}-\overset{\text{O}}{\parallel}{\text{C}}-\text{CH}_2-\overset{\text{O}}{\parallel}{\text{C}}-\text{O}-\text{C}_5\text{H}_{11}$	400	1000	355
Malonic acid	$\text{HO}-\overset{\text{O}}{\parallel}{\text{C}}-\text{CH}_2-\overset{\text{O}}{\parallel}{\text{C}}-\text{OH}$	-	-	-
Dimethyl malonate	$\text{H}_3\text{CO}-\overset{\text{O}}{\parallel}{\text{C}}-\text{CH}_2-\overset{\text{O}}{\parallel}{\text{C}}-\text{OCH}_3$	250	800	280
Acetylacetone	$\text{H}_3\text{C}-\overset{\text{O}}{\parallel}{\text{C}}-\text{CH}_2-\overset{\text{O}}{\parallel}{\text{C}}-\text{CH}_3$	2000	6600	412
Acetoacetanilide		6100	4600	368

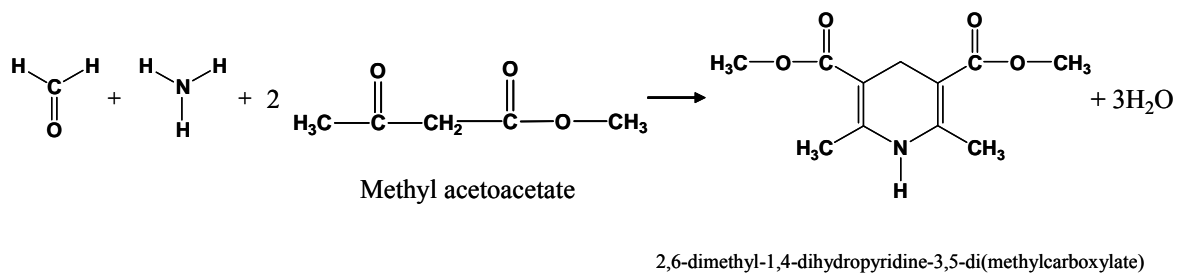

**Scheme 1** The detection reaction using methyl acetoacetate as a reagent for formaldehyde detection in the presence of ammonia.

### 3.2. Selection of detection wavelength

A series of standard solutions were prepared according to the standard procedure, and the absorption maximum wavelength was obtained in the range of 300-500 nm by a spectrophotometer. The maximum absorption wavelength of the product was 375 nm as is shown in Fig. 2.

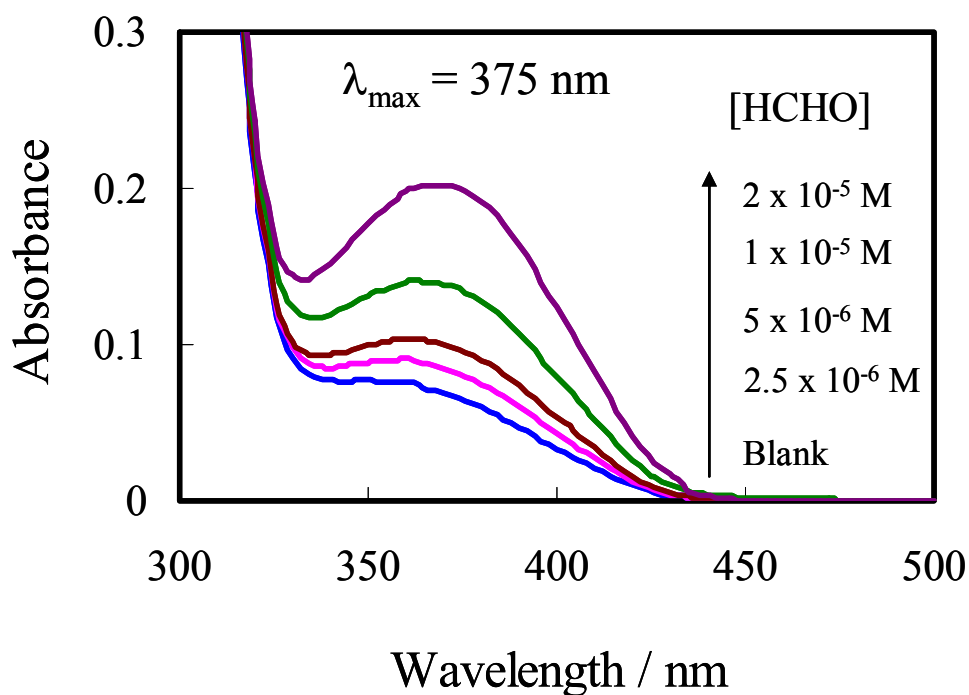

**Fig. 2** Absorption spectra for the product of formaldehyde in the concentration range of 2.5 – 20 × 10<sup>-6</sup> M.

### **3.3 Optimization of manifold parameters for spectrophotometric determination of formaldehyde by FIA**

In order to obtain a maximum signal to noise ratio in the spectrophotometric determination of formaldehyde, manifold parameters are optimized using the FIA manifold with LED detector in Fig. 1. To optimize the conditions,  $5 \times 10^{-6}$  and  $10 \times 10^{-6}$  M of formaldehyde solution were injected into the FI system.

The effect of the reaction coil temperature was firstly examined by varying the temperature from 25 to 80 °C using the dry heating bath. As shown in Fig. 3, the dependence of the overall reaction on temperature was significant. The higher the reaction temperature is, the larger the analytical signals are, and the higher sensitivity is obtained. On the other hand, a temperature above 70 °C gave poor reproducibility because the baseline is not stable and some air bubbles can occur. Therefore, a reaction temperature of 65 °C was maintained by keeping the reaction coil in a thermostating dry bath.

The sensitivity for the determination of formaldehyde also depended on the reaction time. The effect of the flow rate of the carrier and the reagent solution was investigated in the range of 0.2 to 0.6 mL min<sup>-1</sup>. The results shown in Fig. 4 indicate that with increasing flow rate from 0.2 to 0.6 mL min<sup>-1</sup>, the sensitivity of the detection of formaldehyde was

lowered. However, too low flow rates could lead to poor reproducibility and sample throughput. As a compromise between sensitivity and sampling rate,  $0.4 \text{ mL min}^{-1}$  of the flow rate was chosen in the further experiments.

Longer reaction coils gave a longer residence time, but the dispersion of the sample zone became larger, and the output peaks were broadened. The effect of mixing coil length was examined by varying the length from 4 m to 12 m. As shown in Fig. 5, the signal peak height increased with increasing the mixing coil length up to 8 m, and above 8 m, signal peak height was almost identical. A reaction coil length of 10 m was chosen as a compromise with respect of the sensitivity and the sample throughput.

The sample injection volumes of 100, 200, 300, 400 and 500  $\mu\text{l}$  were examined by changing the length of the sample loop on the injection valve. The results obtained in Fig. 6 showed that larger volumes were preferable to obtain higher peak, and the volumes above 300  $\mu\text{l}$  gave only a small increase in peak height: the sample volume of 300  $\mu\text{l}$  was selected as a compromise of the sensitivity, the sample throughput and the sample size.

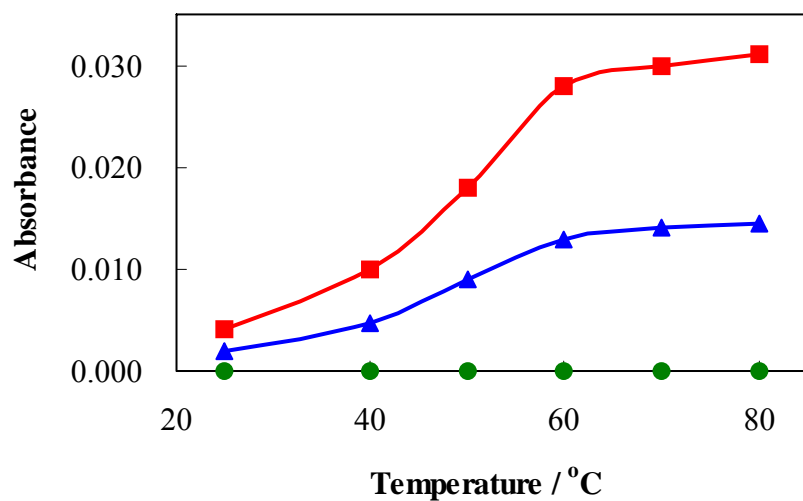

**Fig. 3** Effect of reaction temperature.

HCHO concentration, ●: 0 (blank); ▲:  $5 \times 10^{-6}$  M; ■:  $10 \times 10^{-6}$  M.

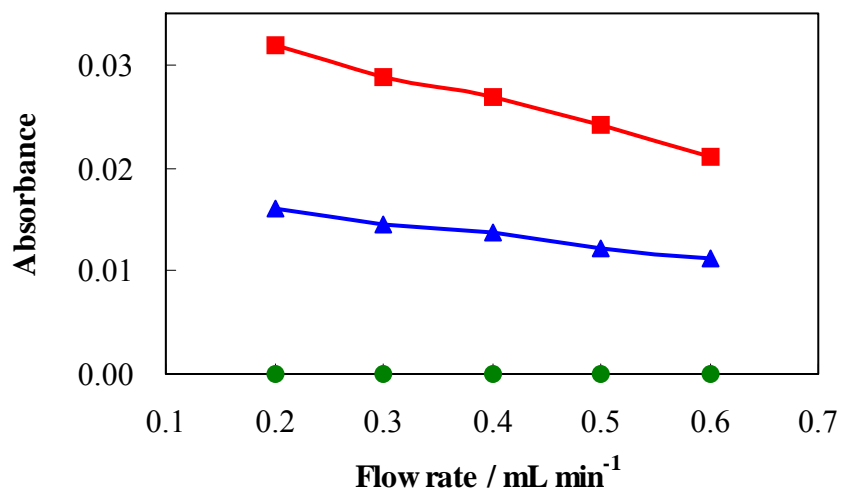

**Fig. 4** Effect of flow rate.

HCHO concentration, ●: 0 (blank); ▲:  $5 \times 10^{-6}$  M; ■:  $10 \times 10^{-6}$  M.



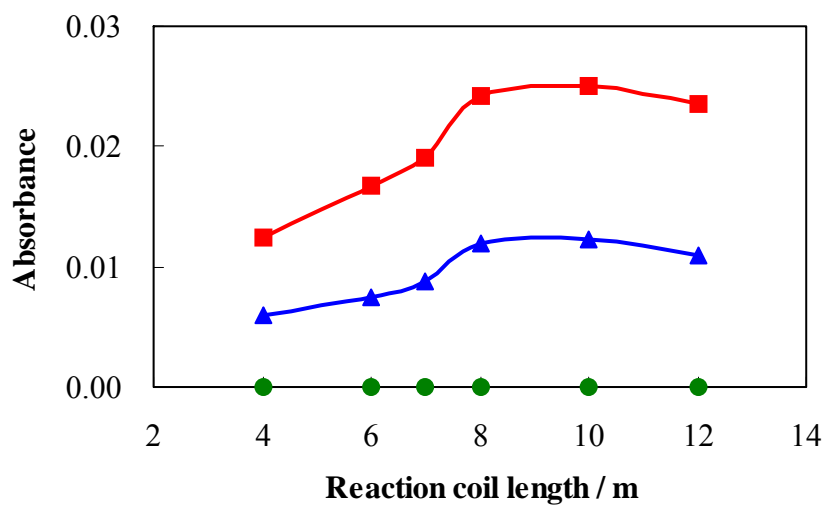

**Fig. 5** Effect of mixing coil length.

HCHO concentration, ●: 0 (blank); ▲: 5 x 10<sup>-6</sup> M; ■: 10 x 10<sup>-6</sup> M.

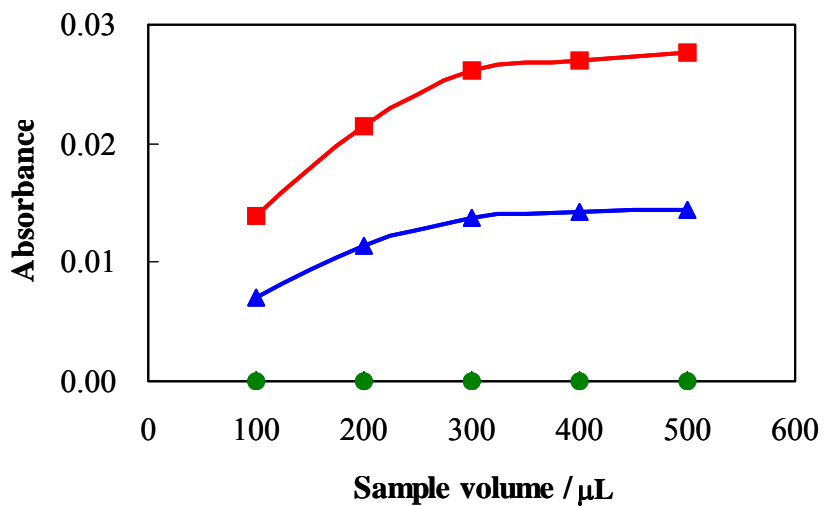

**Fig. 6** Effect of sample volume.

HCHO concentration, ●: 0 (blank); ▲: 5 x 10<sup>-6</sup> M; ■: 10 x 10<sup>-6</sup> M.

### **3.4 Optimization of reagent concentrations for spectrophotometric determination of formaldehyde**

The effect of methyl acetoacetate concentration in the range of 0.01 ~ 0.2 M on the sensitivity was studied. The results in Fig. 7 indicate that the peak height increased with increasing methyl acetoacetate concentrations up to 0.1 M, above which the signal intensity was almost identical. In this study, 0.1 M methyl acetoacetate was selected.

In the reaction of formaldehyde with the proposed reagent, pH of the reagent solution is very important for the reaction efficiency. The influence of three kinds of buffer on the sensitivity was examined; they were an acetate buffer (acetic acid–sodium acetate), a phosphate buffer (disodium hydrogenphosphate – potassium dihydrogenphosphate), and an ammonium acetate buffer. All the buffers tested here were prepared at the total concentration of 1.0 M with pH of 7. The first two buffers were not adequate because of very low analytical signals. The best results were obtained with the ammonium acetate buffer, and therefore the effect of pH on the sensitivity was investigated with the ammonium acetate buffer in the range of pH 5.0 ~ 8.0: the pH was adjusted by adding an acetic acid or a NaOH solution to the ammonium acetate solution. The results obtained in Fig. 8 indicates that in the pH range over 6.5 ~ 7.5, the peak height is highest and almost identical, whereas below pH 6.5 and above pH 7.5, the peak height becomes shorter. From

such results, the pH of 7.0 was chosen for further experiments.

Ammonium acetate can act as one of the components of the reagents in the proposed method. The effect of ammonium acetate concentration was examined in the range of 0.1 ~ 2.0 M. The results obtained are shown in Fig. 9. It was found that the peak height increased with increasing ammonium acetate concentration till 1.0 M, above which no further increase was observed; In the proposed method, 1.0 M ammonium acetate was selected because of stronger buffer capacity, higher sensitivity and better baseline.

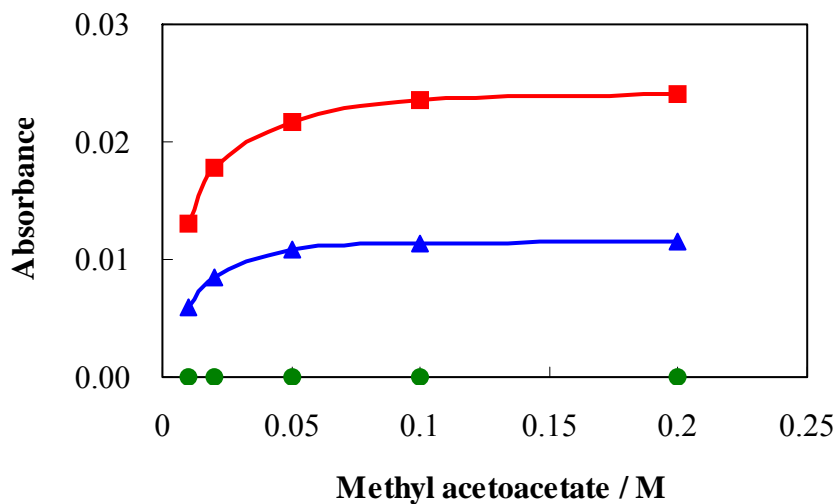

**Fig. 7** Effect of concentration of methyl acetoacetate.

HCHO concentration, ●: 0 (blank); ▲:  $5 \times 10^{-6}$  M; ■:  $10 \times 10^{-6}$  M.

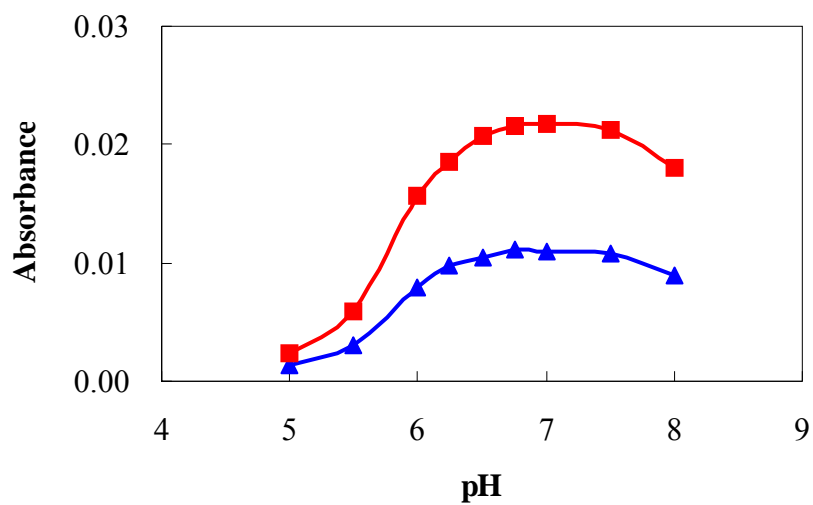

**Fig. 8** Effect of pH.

HCHO concentration, ●: 0 (blank); ▲:  $5 \times 10^{-6}$  M; ■:  $10 \times 10^{-6}$  M.

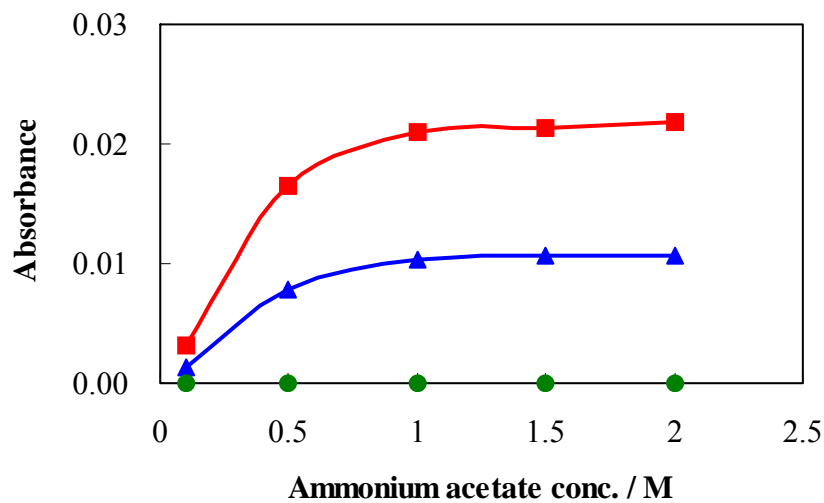

**Fig. 9** Effect of concentration of ammonium acetate.

HCHO concentration, ●: 0 (blank); ▲:  $5 \times 10^{-6}$  M; ■:  $10 \times 10^{-6}$  M.

### 3.5 Interference from foreign substances

The investigation of possible interferences was conducted with regard to possible chemical interferences and the problem of selectivity. The interference of low molecular weight aldehydes, such as acetaldehyde, and propionaldehyde, as well as other compounds, were checked and was found negligible even when interfering substances were added in very large excess amounts of the formaldehyde levels. In the Hantzsch reaction, aldehydes can react with ammonia and  $\beta$ -diketone analogues to form dihydropyridine derivatives as in Scheme 1, and therefore this reaction is very selective to aldehyde. In the reaction with methyl acetoacetate, the selectivity to formaldehyde can be more improved, because methyl acetoacetate can restrict the conformation of flexibility, and other aldehydes, such as acetaldehyde and propionaldehyde, are more difficult to react, compared to formaldehyde. Of the co-existing substances, more than  $5 \times 10^{-6}$  M of sulfite ion decreased the peak height seriously. This interference is due to the reaction of formaldehyde with sulfite. Though sulfite can easily react with formaldehyde, only a low concentration of sulfite can exist in natural waters.  $\text{H}_2\text{O}_2$  and  $\text{I}_2$  solutions at low concentrations are not so strong oxidizing agents and can not oxidize formaldehyde. Therefore, the proposed method is free from interference with the determination of formaldehyde in environmental waters. Table 2 shows the tolerable concentration defined as the concentration of foreign species causing less than  $\pm 5\%$  relative error.

**Table 2** Tolerable concentration of foreign species in the determination of  $5 \times 10^{-6}$  M formaldehyde

Foreign substances	Tolerable conc. (M)	Tolerable limit <sup>a</sup> ( [species] / [HCHO] )	Relative error (%)
H <sup>+</sup>	$4 \times 10^{-2}$	8000	- 4.7%
Na <sup>+</sup> , Cl <sup>-</sup>	$2.5 \times 10^{-2}$	5000	+ 4.7%
OH <sup>-</sup>	$1 \times 10^{-2}$	2000	-2.8%
Br <sup>-</sup>	$1 \times 10^{-2}$	2000	+ 0.8%
Ca <sup>2+</sup>	$1 \times 10^{-2}$	2000	+ 2.7%
SO <sub>4</sub> <sup>2-</sup>	$1 \times 10^{-2}$	2000	+1.3%
NO <sub>3</sub> <sup>-</sup>	$1 \times 10^{-2}$	2000	+ 3.7%
Ethanol	$1 \times 10^{-2}$	2000	+ 0.8%
Acetone	$1 \times 10^{-2}$	2000	+ 4.7%
CO <sub>3</sub> <sup>2-</sup>	$5 \times 10^{-3}$	1000	- 3.5%
NO <sub>2</sub> <sup>-</sup>	$2 \times 10^{-3}$	400	+ 3.7%
H <sub>2</sub> O <sub>2</sub> , I <sub>2</sub>	$2 \times 10^{-3}$	400	+ 4.2%
Propionaldehyde	$5 \times 10^{-4}$	100	+ 4.7%
Acetaldehyde	$2 \times 10^{-4}$	40	+ 3.0%
Cu <sup>2+</sup>	$3 \times 10^{-5}$	6	+ 2.7%
Fe <sup>3+</sup>	$2 \times 10^{-5}$	4	+ 4.3%
SO <sub>3</sub> <sup>2-</sup>	$5 \times 10^{-6}$	1	- 4.5%

<sup>a</sup> Defined as  $\pm 5\%$  relative error

### 3.6 Calibration graph and analytical features

Under the optimal conditions, the calibration graph was prepared over the range of  $0.25 \sim 20.0 \times 10^{-6}$  M formaldehyde with a correlation coefficient of 0.9998. The peak profiles of formaldehyde for the calibration graph obtained are shown in Fig. 10: the equation of the calibration graph was expressed as  $Y = 0.0023X + 3E-06$ , where Y was peak height and X was formaldehyde concentration in  $10^{-6}$  M. The relative standard deviation of 12 replicate injections of  $5 \times 10^{-6}$  M was 1.2 %.

The limit of detection, calculated as the concentration corresponding to three times of the baseline noise (3 S/N), was  $5 \times 10^{-8}$  M ( $1.5 \mu\text{g L}^{-1}$ ).

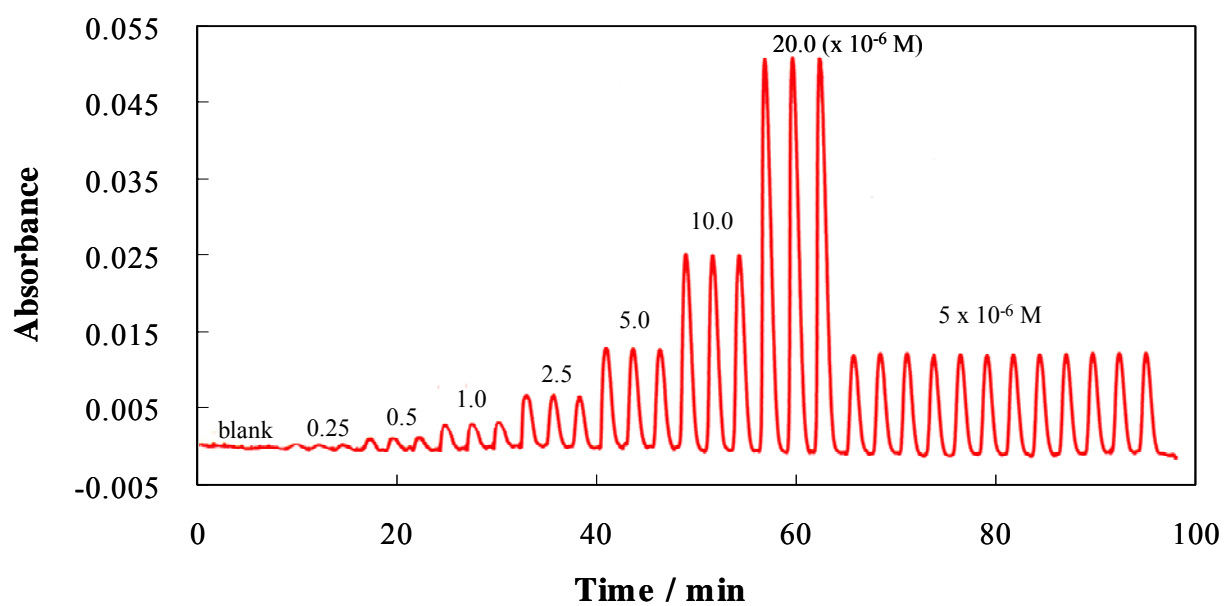

**Fig. 10** Flow signals for formaldehyde determination.

HCHO concentration: 0-20 x 10<sup>-6</sup> M; 0.1 M methyl acetoacetate; 1.0 M ammonium acetate; pH 7.0; flow rate: 0.4 mL min<sup>-1</sup>; reaction coil length: 10 m; sample injection volume: 300 μL; reaction temperature: 65 °C.



### **3.7 Determination of formaldehyde in natural water samples**

The developed procedure was applied to the determination of formaldehyde in natural water samples. Different real water samples (tap water, river water and rainwater) were analysed. The samples were filtered through a filter paper prior to their analysis. Recovery tests were performed on the formaldehyde solutions of different concentrations from 3.0 to 15.0  $\mu\text{g L}^{-1}$ . Significantly good recoveries from 98.3 to 106.7 % were obtained from the determination of formaldehyde in water samples (Table 3).

In order to evaluate the accuracy of the proposed method, the results obtained were compared with those obtained with an acetylacetone/spectrophotometric method and acetoacetanilide/fluorometric method described in the previous papers [30, 38]. Rainwater samples 1, 2, and 3 were collected in Okayama University campus in the different day in December 2006. The good agreement between these results (Table 4) indicates the successful applicability of the proposed method for the determination of formaldehyde.

**Table 3** Analytical results for the determination of formaldehyde in natural water samples

Sample	HCHO found / $\mu\text{g L}^{-1}$	HCHO added / $\mu\text{g L}^{-1}$	HCHO / $\mu\text{g L}^{-1}$		Recovery (%)
			found	recovered	
Tap water	$4.3 \pm 0.2$	3.0	$7.5 \pm 0.1$	3.2	107
		6.0	$10.6 \pm 0.2$	6.3	105
River water	$5.2 \pm 0.2$	3.0	$8.3 \pm 0.2$	3.1	103
		6.0	$11.5 \pm 0.1$	6.3	105
Rainwater	$15.7 \pm 0.1$	6.0	$21.6 \pm 0.2$	5.9	98
		15.0	$30.5 \pm 0.1$	14.8	99

All values are means ( $n = 5$ ) with  $\pm \sigma$  (standard deviation).

**Table 4** Comparison of the results obtained by the proposed method and other methods<sup>a</sup>

Rainwater	HCHO conc. found / $\mu\text{g L}^{-1}$		
	Proposed method	Acetylacetone method	Acetoacetanilide method
1	$17.8 \pm 0.2$	$18.3 \pm 0.2$	$17.2 \pm 0.1$
2	$13.5 \pm 0.1$	$14.0 \pm 0.1$	$13.0 \pm 0.2$
3	$15.7 \pm 0.1$	$16.5 \pm 0.1$	$16.0 \pm 0.1$

<sup>a</sup> Acetylacetone/spectrophotometric method and acetoacetanilide/fluorometric method were described in the previous papers [30, 38].

## **4 Conclusion**

A novel water-soluble reagent, methyl acetoacetate, was for the first time proposed for the determination of formaldehyde.

A simple and highly sensitive detection method based on the reaction of formaldehyde with methyl acetoacetate and ammonia was developed.

Flow injection system with a LED detector was used for spectrophotometric detection of formaldehyde as a highly sensitive detection method.

The proposed method can be directly applied to the determination of formaldehyde in natural water samples.

## **5 References**

- [1] U.S. Environmental Protection Agency, Office of Air and Radiation. Report to Congress on Indoor Air Quality, Volume II: Assessment and Control of Indoor Air Pollution, 1989.
- [2] Occupational Safety and Health Guideline for Formaldehyde, in Occupational Safety and Health Guidelines for Chemical Hazards. Cincinnati, National Institute for Occupational Safety and Health, 1988.

- [3] R.J. Kieber, M.F. Rhines, J.D. Willey, G.B. Avery, *Atmos. Environ.* 33 (1999) 3659.
- [4] W.H. Glaze, M. Koga, D. Cancilla, *Environ. Sci. Technol.* 23 (1989) 838.
- [5] G. Becher, N. M. Ovrum, R. F. Christman, *The Science of the Total Environment* 117/118 (1992) 509.
- [6] R.G. Liteplo, R. Beauchamp, M.E. Meek, R. Chenier, *Concise international chemical assessment document 40: formaldehyde*, World Health Organization, Geneva, 2002.
- [7] S.W. Krasner, M.J. McGuire, J.G. Jacangelo, N.L. Patania, K.M. Reagan, E.M. Aieta, *J. Am. Water Works Assoc.* 81 (1989) 41.
- [8] B.A. Tomkins, J.M. McMahon, W.M. Caldwell, D. Wilson, *J. Assoc. Off. Anal. Chem.* 72 (1989) 835.
- [9] C-F. Tsai, H-W. Shiau, S-C. Lee, S-S. Chou, *J. Food. Drug Analysis* 11 (2003) 46.
- [10] N. Kiba, L.M. Sun, S. Yokose, M.T. Kazue, T.T. Suzuki, *Anal. Chim. Acta* 378 (1999) 169.
- [11] J. Ramer, M.L. Holland, D.P. Wiesler, M. Novotny, *Anal. Chem.* 56 (1984) 962.
- [12] E. Sawicki, T.R. Hauser, S. McPherson, *Anal. Chem.* 34 (1962) 1460.
- [13] A.P. Altshuller, J.D. Miller, *Anal. Chem.* 33 (1961) 621.
- [14] G.W. Harris, G.I. Mackay, T. Iguchi, L.K. Mayne, H.I. Schiff, *J. Atmos. Chem.* 8 (1989) 119.
- [15] T.G. Matthews, T.C. Howell, *J. Air Pollute Control Assoc.* 31(1981)1181.

- [16] E. Sawicki, T.R. Hauser, T.W. Stanley, *Anal. Chem.* 33 (1961) 93.
- [17] K. Toda, K-I. Yoshioka, K. Mori, S. Hirata, *Anal. Chim. Acta* 531 (2005) 41.
- [18] JIS K 0303, Method for determination of formaldehyde in flue gas. Japanese Industrial Standards Committee, Tokyo, 1993.
- [19] M.S. Qoesenberry, Y.C. Lee, *Anal. Biochem.* 234 (1996) 50.
- [20] K. Kawamura, K. Kerman, M. Fujihara, N. Nagatani, T. Hashiba, E. Tamiya, *Sensors and Actuators B* 105 (2005) 495.
- [21] R.R. Miksch, D.W. Anthon, L.Z. Fanning, C.D. Hollowell, K. Revzan, J. Glanville, *Anal. Chem.* 53 (1981) 2118.
- [22] M.P. Munoz, F.J.M. de Villena Rueda, L.M.P. Diez, *Analyst* 114 (1989) 1469.
- [23] S. Dong, P.K. Dasgupta, *Environ. Sci. Technol.* 21 (1987) 581.
- [24] P.K. Dasgupta, K. DeCesare, J.C. Ullrey, *Anal. Chem.* 52 (1980) 1912.
- [25] E. Fagnani, C.B. Melios, L. Pezza, H.R. Pezza, *Talanta* 60 (2003) 171.
- [26] E. Sawicki, T.R. Hauser, T.W. Stanley, W. Elbert, *Anal. Chem.* 33 (1961) 93.
- [27] E.A. Pereira, P.K. Dasgupta, *Int. Environ. J. Anal. Chem.* 66 (1997) 201.
- [28] T.G. Matthews, *Am. Ind. Hyg. Assoc. J.* 43 (1982) 547.
- [29] S.T. Girousi, E.E. Golia, A.N. Voulgaropoulos, A.J. Maroulis, *Fresenius' J. Anal. Chem.* 358 (1997) 667.
- [30] T. Nash, *Biochem. J.* 55 (1953) 416.

- [31] S. Belman, *Anal. Chim. Acta* 29 (1963) 120.
- [32] E. Sawicki, R.A. Carnes, *Mikrochim. Acta* (1968) 148.
- [33] B.J. Compton, W.C. Purdy, *Anal. Chim. Acta* 119 (1980) 349.
- [34] Q. Li, P. Sritharathikhun, M. Oshima, S. Motomizu, *Anal. Sci.* 23 (2007) 413.
- [35] J. Li, P.K. Dasgupta, Z. Genfa, M.A. Hutterli, *Field Anal. Chem. Technol.* 5 (2001) 2.
- [36] T. Sakai, S. Tanaka, N. Teshima, S. Yasuda, N. Ura, *Talanta* 58 (2002) 1271.
- [37] P. Sritharathikhun, M. Oshima, S. Motomizu, *Talanta* 67 (2005) 1014.
- [38] Q. Li, M. Oshima, S. Motomizu, *Talanta* 72 (2007) 1675.
- [39] N. Kiba, L.M. Sun, S. Yokose, M.T. Kazue, T.T. Suzuki, *Anal. Chim. Acta* 378 (1999) 169.
- [40] E. Cotsaris, B.C. Nicholson, *Analyst* 118 (1993) 265.
- [41] K. Takami, K. Kuwata, A. Sugimae, M. Nakamoto, *Anal. Chem.* 57 (1985) 243.
- [42] <http://www.inchem.org/documents/cicads/cicads/cicad40.htm#3>. Concise International Chemical Assessment Document 40. Formaldehyde (CICADS 40, 2002).