

Fine Particles of Ti and Ti-Mo Alloy Prepared by Gas Evaporation

Masayuki UMEMOTO*, Yoshito TAKEMOTO*,
Akira SAKAKIBARA* and Moritaka HIDA*

(Received January 9, 1990)

SYNOPSIS

Fine particles of Ti-Mo alloy were prepared by evaporation. When Ti-40at%Mo alloy was evaporated on tungsten filament, fine particles of Ti contaminated with W were obtained. These particles were polyhedron in shape and 10~250nm in diameter. Average diameter and size distribution increased with pressure of argon gas(100~600 Torr). When pure Ti was placed on the Mo filament and evaporated from melt down of heated Mo filament in helium gas, fine particles of pure Ti and of Ti-Mo alloy were obtained. In this case, Ti particles were of indeterminate form and of several tens nm in diameter, and their diffraction pattern was of common α -Ti. On the other hand, composition of the Ti-Mo particles was determined to be 18at%Mo by an analysis of EDX. Structure of Ti-Mo particles could not be determined because their diameters were more than 600nm. The temperature of Mo filament, for the most part, was about 1800^oC, and there pure Ti particles were produced. The temperature of the fused part of the filament was locally higher than 2600^oC, and there Ti-Mo particles were produced. Fine structures of contact region among some Ti particles were observed with HRTEM.

* Department of Mechanical Engineering

1. INTRODUCTION

In case of fine particles of pure metals, Cr, Mn, etc., new modification in structure and new phase were reported previously.⁽¹⁾ Large number of studies were carried out on fine particles of pure metals, but a few on alloys, such as Fe-Co, Fe-Ni, Fe-Co-Ni, Ag-Pd, Au-Ni, Fe-Ni, Ni-Pd^{(2),(3)}, Cr-Ni, Cr-Co and Cr-Fe⁽⁴⁾ of which vapor pressures of the components were close each other. In the case of preparing alloy particles by evaporation of mother alloy, the composition of the mother alloy may be almost identical to that of the particles if the vapor pressures of the components are close each other, but it is expected to be difficult to maintain the composition of the mother alloy for the particles if the vapor pressures are very different.

Many works have been made on bulk Ti-Mo alloys,⁽⁵⁾ including those of the present authors. Structure of pure Ti is hcp(α -Ti) at room temperature and bcc(β -Ti) at high temperature. The high temperature β phase can not be quenched even with rapid cooling. On the other hand, β -phase is stable in Ti-Mo alloy containing more than 45at% of Mo. In the case of alloys containing less than 30at%Mo, however, metastable β -phase can be obtained at room temperature by rapid cooling from β -phase region in phase diagram. In the alloy containing less than 6at%Mo, martensite may be formed with rapid cooling from β -phase field (Fig.1). It is interesting to study how these structures and phase transformation in bulk specimen are modified in fine particles.

From these points of view, preparing Ti-Mo fine alloy particles, of which the components are remarkably different in melting point and vapor pressure, was tried by gas evaporation method taking care of selection of filament and evaporated material.

2. EXPERIMENTAL PROCEDURES

Evaporation was carried out in the stainless steel work chamber of approximately 3 liters in volume shown in Fig.2. After air was evacuated to about 6.0×10^{-6} Torr from the work chamber, the valve between the molecular turbo pump and the work chamber was closed and argon or helium gas was introduced into the work chamber. Prescribed pressure(100, 300 and 600 Torr of Ar, and 300 Torr of He gas) was

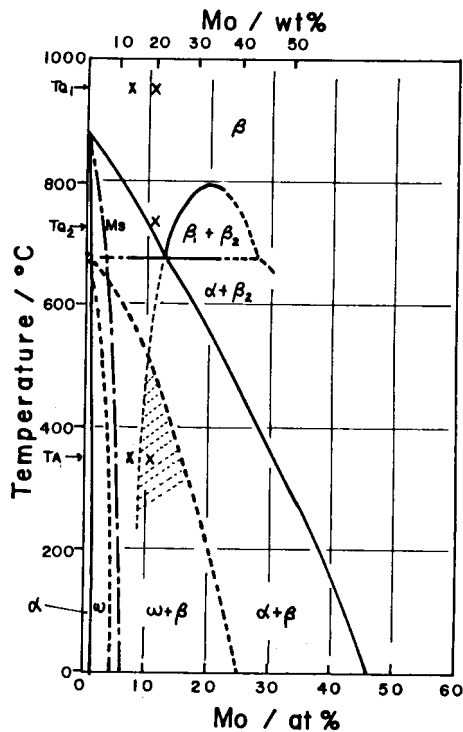

Fig.1 Ti-Mo phase diagram.

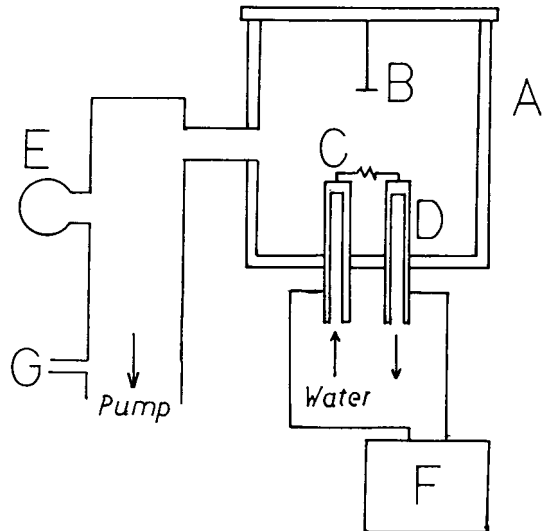

Fig.2 Apparatus for gas evaporation. A:work chamber, B:microgrid, C:filament, D:water-cooled terminal, E:vacuum gauge, F:power source, G:gas inlet.

attained in a short time of about half a minute and then evaporation was carried out in one minute. The as-evacuated vacuum changed to 5×10^{-5} Torr in one minute after closing the main valve, so that contamination of fine particles was less than this vacuum level. Purity of Ar and He gas used was 6N.

Conical baskets made of tungsten wire, 1.3mm in diameter, and of molybdenum wire, 1.5mm in diameter, were used for evaporation. Ti-40at%Mo mother alloy, 15mg, was evaporated with tungsten filament in Ar gas. Pure Ti, 15mg, was evaporated in He gas with molybdenum filament, which was expected to melt and evaporate together with Ti. The temperature of the basket heater and molten metal was checked with the infra-red radiation thermometer, THERMOMASTER LEC-KTL-520A, which was calibrated with the melting points of Ag and Ti in W basket. The thermometer overestimated the melting points by nearly 50°C .

The particles were deposited onto copper specimen grids carrying Triafol (cellulose acetobutyrate) films backed with evaporated carbon. The grids were placed at 10cm above the heater.

The particles were observed with JEM-100S, EM-002B, and H-800 electron microscopes. The composition of the particles was analyzed

with an EDX(Energy Dispersive X-ray Spectroscopy) equipped with the latter two electron microscopes.

3. RESULTS AND DISCUSSION

3.1 Evaporation of Ti-40at%Mo Alloy

Ti-40at%Mo mother alloy was evaporated with tungsten filament in Ar gas of 100, 300 and 600 Torr. The temperature of tungsten filament was about 2000°C when the alloy was evaporated. The fine particles thus produced were composed almost of Ti with contamination of W that amounted to 5at%, and did not contain Mo, as shown in Fig.3. Evaporation of the mother alloy was also carried out in vacuum, but Mo was not detected from the particles. Absence of Mo in the particles was owing to the fact that the vapor pressure Mo at 2000°C was 1×10^{-5} Torr, extremely lower than that of Ti, 2×10^{-1} Torr. The fine particles of Ti obtained were polyhedral and 10~250nm in diameter. Average size of the particles increased and their size distribution broadened with increasing gas pressure, as shown in Photo 1.

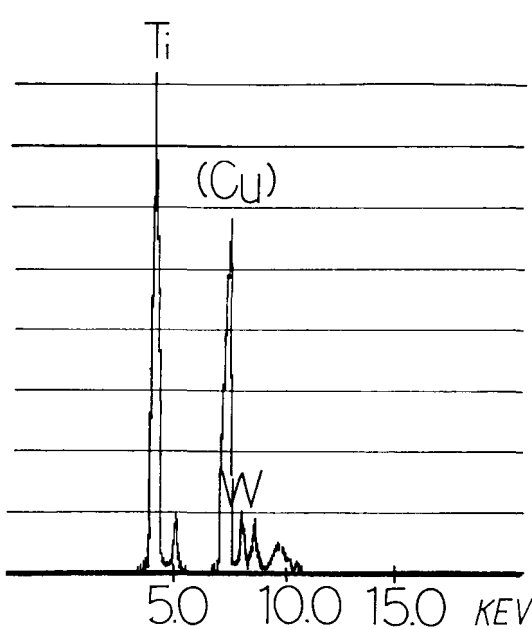

Fig.3 EDX curve of Ti particles prepared by evaporation of Ti-40%Mo with W filament.

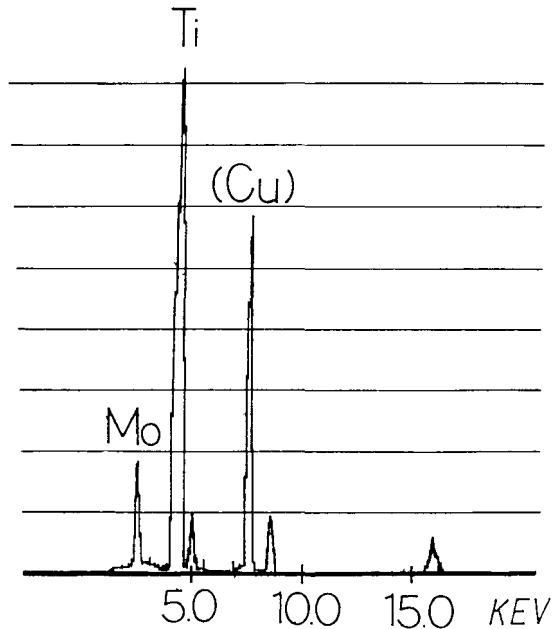
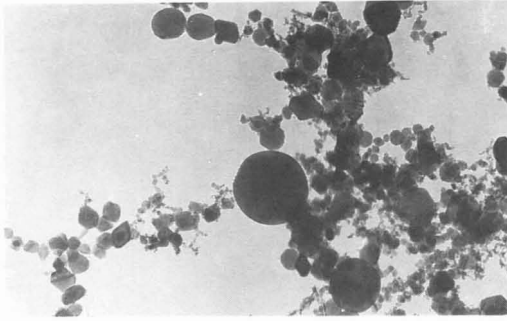
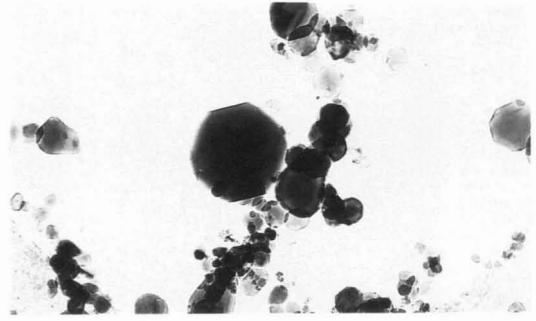

Fig.4 EDX curve of Ti-Mo particles prepared by evaporation of Ti with Mo filament.



(a) 200nm



(b) 200nm

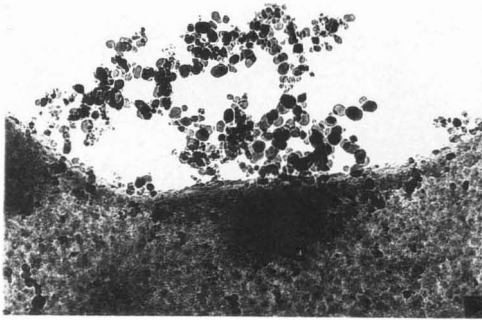

(c) 100nm

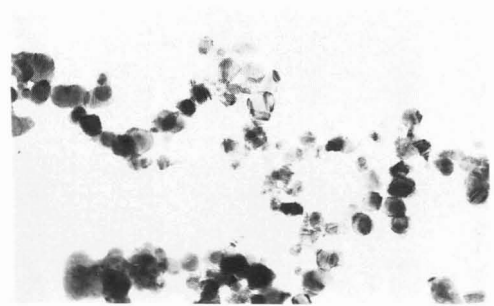

(d) 100nm

Photo 1 Electron micrographs of Ti particles prepared by evaporation of Ti-40%Mo in Ar gas with W filament. Pressure of Ar gas; (a) 600 Torr, (b) 300 Torr, (c) and (d) 100 Torr.

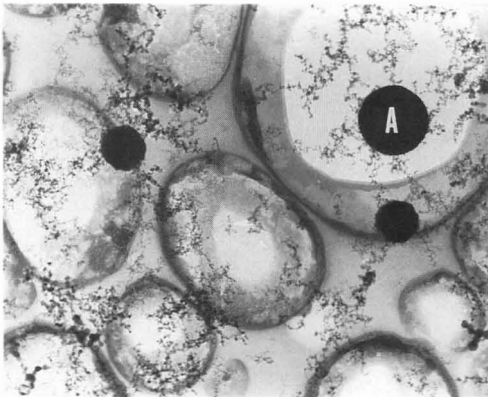

(a) 500nm

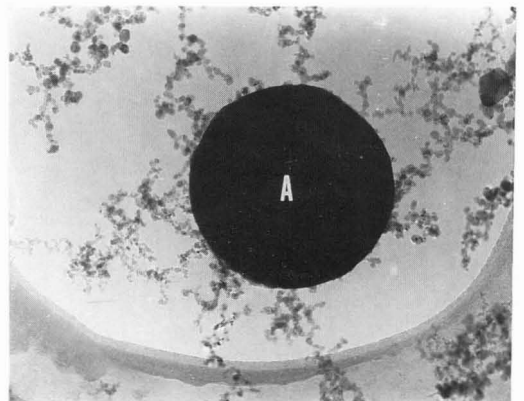

(b) 200nm

Photo 2 Electron micrographs of Ti-Mo large particles and pure Ti small ones prepared by evaporation of Ti in He gas with Mo filament.

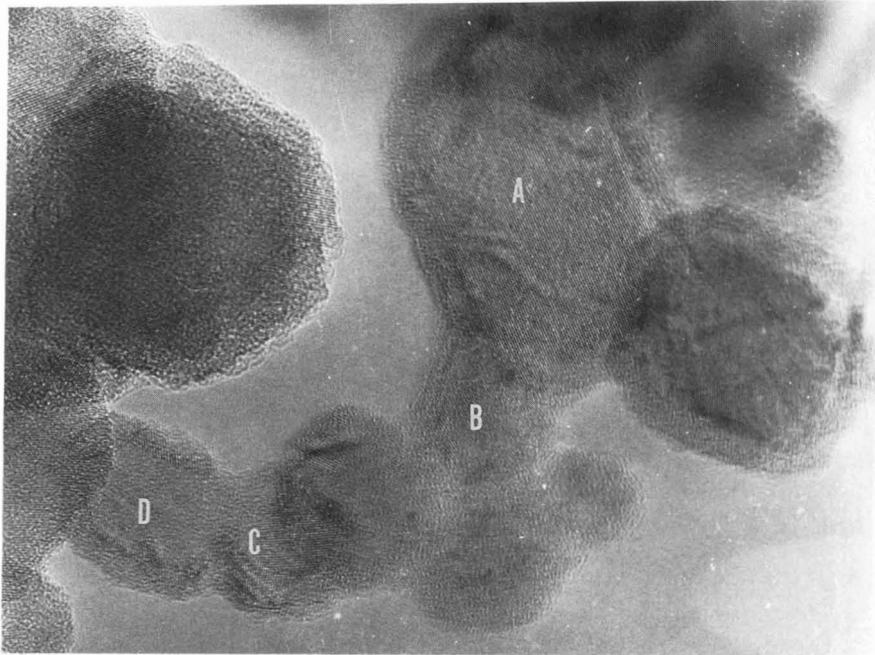

(a) $\underline{10 \text{ nm}}$

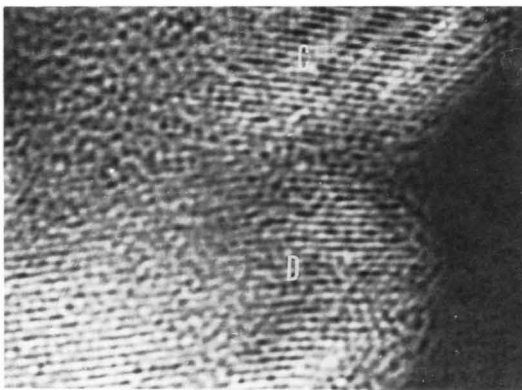

(b) $\underline{1 \text{ nm}}$

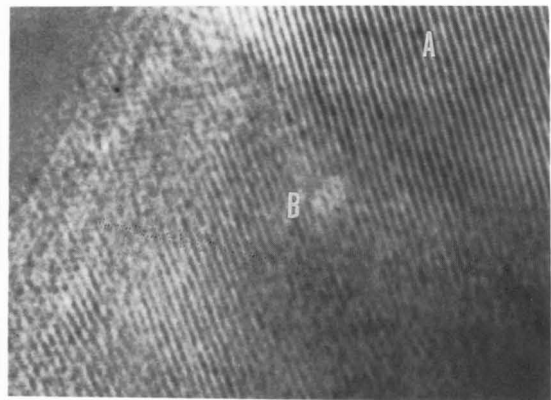

(c) $\underline{1 \text{ nm}}$

Photo 3 Electron micrographs of; (a) pure Ti particles being contact each other, (b) and (c) contact region.

3.2 Evaporation of Ti Using Mo Filament

When a piece of Ti was charged in the basket of Mo filament and temperature was elevated in He of 300 Torr, Ti melted at first and then Mo filament melted down locally in less than 10s. If filament melted down fortunately at the position where Ti was placed, fine particles of Ti-Mo alloy was able to be produced. Contamination with W from the filament, above mentioned, was avoided in this procedure.

Fine particles thus produced consisted of two types; particles of pure Ti and those of Ti-Mo alloy, of which the results of EDX analysis are shown in Fig.4. Electron micrograph of the particles is shown in Photo 2. Pure Ti particles were of indeterminate shape and their diameter ranges between 10 and 30nm. Diffraction pattern from the particles were consistent with α -Ti. Fine particles of Ti-Mo alloy were spherical in shape and more than 600nm in diameter. Concentration of Mo in these particles was 18at%, which was enough to obtain β -Ti, but information on the structure could not be obtained because their size was too large for the electron beam to penetrate.

The result that Ti-Mo particles had grown very large was closely related to the evaporating process. Generally, when the pressure of the environmental gas is increased and the filament temperature is elevated, concentration of the evaporated atoms becomes higher near the source material and particles grow larger, because increase of gas pressure suppresses diffusion of evaporated atoms and elevated filament temperature promotes evaporation.⁽⁵⁾ Particles of Ti-Mo alloy were produced when the Mo filament melted locally, at 2600°C, and the evaporation of Ti was prompted near the melted Mo because of this higher temperature. Larger particles were thus produced. Temperature of the Mo basket, excluding the part of local melting, was about 1800°C. Fine particles of pure Ti were produced before the local melting of Mo filament, so that concentration of vaporized Ti atoms was low and particle size was small.

It was reported that fine particles consisting of about one hundred atoms collided and coalesced.⁽⁶⁾⁻⁽⁸⁾ Most of the Ti particles was not found to be separated and they contacted each other and aligned in the shape of necklace. Because, compared with the bulk material, the ratio of surface to volume is large for the fine particles, they are apt to contact each other to reduce the surface energy.⁽⁹⁾ Each particle obtained in this experiment was individually a single crystal, like particle A in Photo 3(a). Deformation of lattice observed in particle C (about 10nm in diameter) in Photo 3(a)

and (b), is considered to be caused by the contact with particle D which had different lattice orientation. As the misfit in lattice orientation between the two particles increases, disturbance of lattice near the interface becomes so heavy that there appears an amorphous-like region. Size of the particles C and D may be small enough for the reduction of surface energy to exceed the increase in bulk energy due to lattice distortion induced by the contact. On the other hand, particle A (about 30nm in diameter) had the same orientation as the partner B (about 10nm in diameter), judging from the continuous straight lattice plane (10 \cdot 1) across these particles that is shown in Photo 3(c). Lattice distortion induced by the contact was not observed in such a large particle as A with others. If lattice distortion had occurred in the large particles, bulk energy increase would have exceeded surface energy decrease, so that the contact was not accompanied by lattice distortion. Critical diameter of the lattice distortion is supposed to be about 30nm.

4. CONCLUSION

Preparation of fine particles of Ti-Mo alloy of which the components are appreciably different in the vapor pressure was tried.

It was impossible to prepare fine alloy particles by evaporating Ti-Mo mother alloy on the tungsten filament heater. The fine particles obtained showed α -Ti structure and were contaminated with about 5at%W.

Fine particles of Ti-Mo alloy, about 600nm in diameter, and those of pure Ti, 10~30nm, were produced by heating Ti on the molybdenum filament to the temperature of local melt of the filament. Difference in the diameter between pure Ti particles and Ti-Mo ones was considered to be caused by the difference in the temperature of evaporation.

The alloy particles were too large to be transmitted by electron beam. In order to obtain structural information alloy particles less than 50nm in diameter is necessary to be prepared.

From the lattice fringes obtained with ultra high resolution TEM, the Ti particles were single crystals individually, but lattice distortion was introduced in smaller particles when they contacted each other. Particles larger than 20nm in diameter did not involve lattice distortion and distortion free contact occurred only between

particles of the same orientation. Whether contact of particles involves lattice deformation or not depends on whether then the reduction of surface energy surpasses the increase of bulk strain energy or not.

REFERENCES

- (1) K. Kimoto and I. Nishida, J. Phys. Soc. Jpn., 22(1967), 744.
- (2) Y. Fukano and K. Kimoto, J. Phys. Soc. Jpn., 23(1967), 668.
- (3) K. Kusaka, N. Wada and A. Tasaki, Jpn. J. Appl. Phys., 18(1967), 599.
- (4) N. Yukawa, M. Hida, T. Imura and M. Kawamura, J. Jpn. Inst. Metals, 34(1970), 348.
- (5) for example S. Yatsuya, R. Uyeda and Y. Fukano, Jpn. J. Appl. Phys., 11(1972), 408.
- (6) S. Yatsuya, R. Uyeda and Y. Fukano, Jpn. J. Appl. Phys., 12(1973), 1675.
- (7) D. J. McGinty, J. Chem. Phys., 58(1973), 4733.
- (8) W. D. Kristensen, E. J. Jensen and R. M. J. Cotterill, J. Chem. Phys., 60(1974), 4161.
- (9) C. Kaito, K. Fujita, H. Shibahara and M. Shiojiri, J. Appl. Phys., 47(1967), 5161.